



3SUN B48 Product Line

Installation and Maintenance Manual

Revision 1.0.1

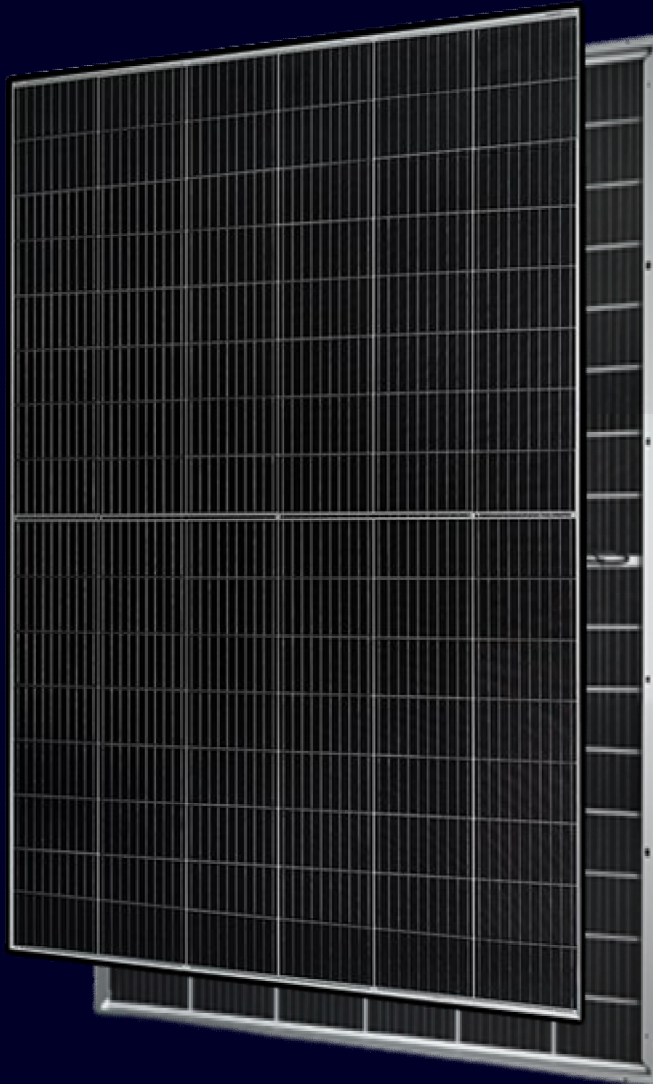

Table 1: List of applicable products

#	Product Family	Product Code
1	3SUN B48	3SHBGA-AF-***
2	3SUN B48*	3SHBGA-CF-***

**known with the Commercial name 3SUN B48LE*



Attention: only qualified personnel can conduct activities on PV systems, such as installation, commissioning, maintenance, and repairs. The safety instructions concerning each system component must be followed and the local codes and regulations regarding health protection, safety and accident prevention must be abided by.

Table of Contents

1. Introduction.....	5
1.1. General Warnings.....	5
1.2. Laws and Regulations.....	5
2. General Information.....	6
2.1. Shipping Configuration.....	6
2.2. Packaging.....	6
2.3. Module Characteristics	7
2.4. Module Identifying Labels.....	8
3. General Safety	9
3.1. Electrical Safety	9
3.2. Fire Safety.....	10
4. Unloading, Transportation and Storage	11
4.1. Container Unloading Procedure.....	11
4.2. Storage Conditions	12
4.3. Secondary Transportation.....	12
4.4. Warnings	14
4.5. Unpacking Sequence	14
4.6. Handling Instructions	16
5. Installation Conditions	18
5.1. Installation Safety.....	18
5.2. Operating Window and Applications	18
5.2.1. Site Selection and Ambient Conditions	18
5.2.2. Applications and System Recommendations	18
5.3. Mechanical Installation and Approved Mounting Configurations	19
5.3.1. General Requirements and Warnings	19
5.3.2. Clamps Installation	20
5.3.3. Bolt or Rivet Installation	22
5.3.4. Installation Configuration Summary.....	25
5.4. Electrical Installation	25
5.4.1. Electrical Performance	25
5.4.2. String Interconnection.....	27
5.4.2.1 Portrait: Daisy-Chain Technique.....	27
5.4.2.2 Portrait: Leapfrog Technique	27
5.4.2.3 Landscape: Daisy-Chain Technique	27
5.4.3. Cables and Connectors	28
5.4.4. Bypass Diode	29
5.4.5. Bonding and Grounding.....	29
6. PV Module maintenance	31
6.1. Module Visual Inspection and Replacement.....	31
6.2. Cleaning.....	31
6.3. Troubleshooting	32
7. Liability Disclaimer	33

1. Introduction

This manual contains information concerning the installation and maintenance instructions and guidelines for 3SUN S.r.l. (“3SUN”) photovoltaic (“PV”) modules. The applicable products are listed in Table 1.

Failure to follow these instructions will void the product warranty and could result in personal injury or damage to the PV system.

3SUN PV modules have been tested and certified by independent agencies according to international standards such as IEC and/or UL. PV modules must be handled, installed, and serviced by qualified personnel with the necessary level of experience and competences. Prior to module installation, the installer must read in detail and understand this manual and the supporting documents. In case of doubts, please contact 3SUN’s customer service through 3SUN’s website www.3SUN.com, or 3SUN’s local representative, before handling, installing, operating and/or maintaining the PV modules. The safety precautions indicated in this document must be followed while handling, installing, operating, and maintaining the PV modules.

In case any conflict would arise between the provisions of this document and local safety regulations, 3SUN’s customer service must be contacted.

1.1. General Warnings

When exposed to sunlight, PV modules generate electricity. Unauthorized and untrained personnel must not touch any PV module part since this can cause harm and injuries such as electric shock or burns.

Prior to handling, connecting, operating, or servicing PV modules, these safety instructions must be read and then complied with. To reduce the risk of injury, do not unpack, install, and conduct maintenance the PV modules unless you are qualified to do so.

Follow these recommendations:

- To guarantee the safety and integrity of the PV system, the installation of PV modules must be carried out by qualified and certified personnel.
- Handling and installation of PV modules is permitted by qualified personnel only after this installation manual has been read and comprehended.
- Do not touch any surface of the PV module without the necessary safety precautions, especially while it is exposed to sunlight and in operation.
- The PV module must be handled by at least two people to prevent drops that can damage it.
- Do not drag or lift the PV module from the PV cables.
- Do not bend, drag, damage, or place heavy objects on the cables.
- Do not drag or lift the PV module from the junction boxes.
- Do not lay or drop objects on the front or rear surface of the PV module.
- Do not stand or walk on the PV modules.
- Do not attempt to modify, disassemble, or fix the PV module without prior authorization from 3SUN’s customer service.
- In case of repairs that entail substitution of parts, make sure that the technician only uses components approved by 3SUN.
- Routine maintenance, including visual inspections, must be performed to verify that the PV modules are operating safely.

1.2. Laws and Regulations

The applicable local regulations which include but are not limited to electrical law and construction law must be considered when mechanical and electrical installations occur. The applicable regulations change depending on the application and on the installed system (DC or AC) voltage. For specific terms, local authorities must be contacted.

2. General Information

2.1. Shipping Configuration

The standard shipping configuration for the PV modules covered by this document includes 28 mono-packs stacked (14 pairs) and loaded into a Maxi Trailer container. Each pack weighs approximately 991 kg and contains 33 PV modules loaded vertically along the long side of the frame. (see overview in Figure 1, Figure 2 and Table 2 below). The instructions for unloading and unpacking the PV modules are in Section 4 of this document.

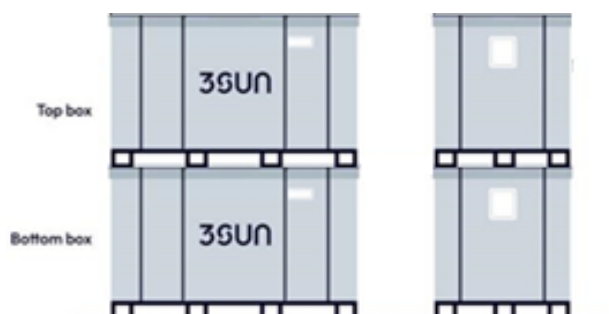

Figure 1: Stacked mono-packs front and side view mono-pack front and side view.

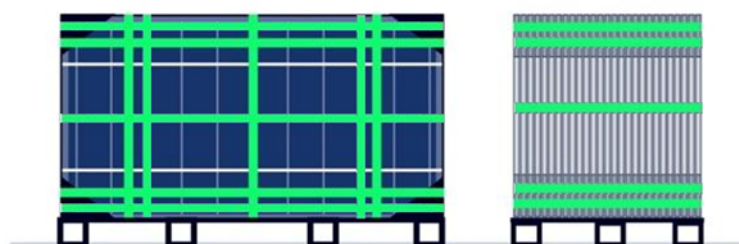

Figure 2: Opened bottom box, front and side view.

Table 2: Mono-pack dimensions and weight.

	Dimensions (LxWxH)	Weight
Mono-pack	1787 x 1063 x 1431 mm	991 kg

2.2. Packaging

Each pack comprises of a wooden pallet on which PV modules are placed, tied, and then covered by a cardboard box with a cardboard top. The unpacking instructions are detailed in Section 4 of this document.

The cardboard of each box has a series of markings (See Table 3 for details) that indicate key instructions about handling or storing. For the complete list of warnings and instructions please refer to this manual.

Table 3: detail of printed markings.

Do not handle sideways or upside-down	RECY focuses on the recycling and disposal of paper and cardboard packaging	Not stackable	Fragile, Handle with care	Keep away from rain and adverse weather conditions	Dispose according to the local norms for corrugated cardboard	Dispose according to the Waste Electrical and Electronic Directive (WEEE)	Compliant with EU safety, health and environmental protection requirements	Scan here for material and recycling details of packaging components

2.3. Module Characteristics

The PV modules of 3SUN’s B48 family are formed by a laminate attached to an aluminum frame and a junction box with cables for system interconnection. The laminate comprises of a front-glass, a rear-glass, encapsulation material and the cell-to-cell interconnection as shown in Figure 3 below. The aluminum frame not only has a structural function but is also the interface with which the PV modules are connected to structures such as trackers with the configurations depicted in Section 5.

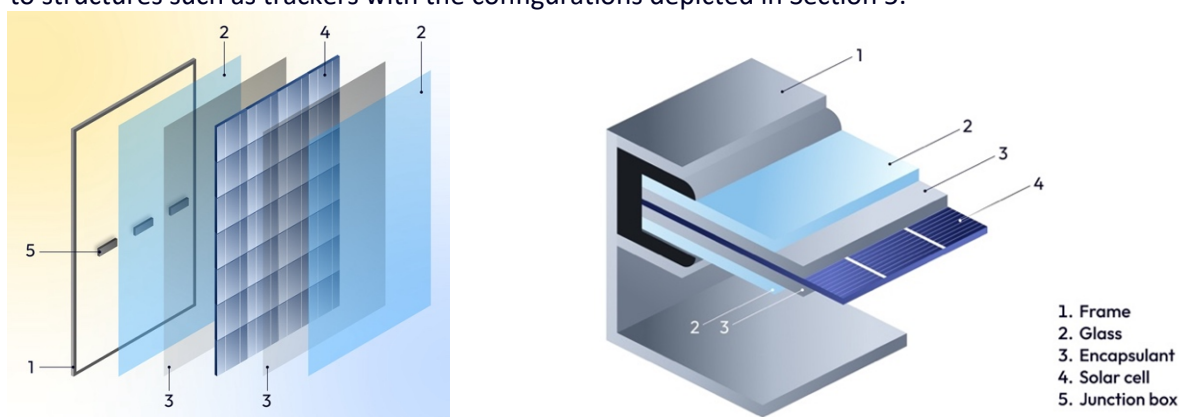

Figure 3: representative PV module cross-sections.

2.4. Module Identifying Labels

Each PV module is shipped with three labels for easy identification:

1. Permanent label: laminated within the module, visible from the front and containing the product serial number and barcode (Figure 4).



Figure 4: example of permanent label.

2. Frame label: placed on the side of the frame and containing the product serial number, the barcode, a QR code, the current class, and the product code (Figure 5).

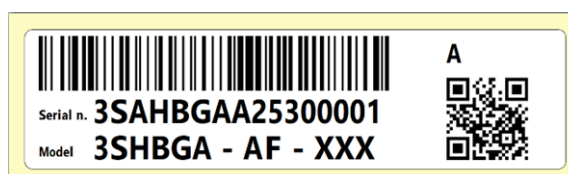

Figure 5: example of frame label.

3. Power label: placed on the rear of the module in proximity to the junction boxes, containing the production date and location, the product serial number, the barcode, a QR code, the current class, the product code, the nominal power, current and voltage, the open circuit voltage, the short circuit current the maximum system voltage and the main certificates (Figure 6).

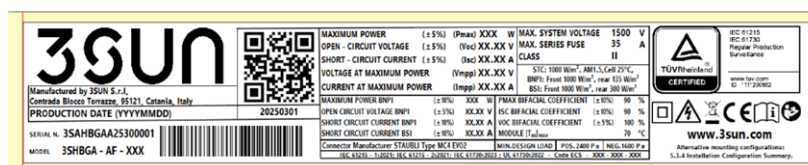

Figure 6: example of module power label

The serial number and the model of the PV modules must be at hand when communicating to 3SUN's customer service.

Type label and JBX are on the back side and this will identify the front side.

3. General Safety

3.1. Electrical Safety

3SUN PV modules have been tested and are certified in compliance to the international safety standards defined currently in IEC 61730:2016 *“Photovoltaic module safety qualification”* while the compliance with IEC 61730:2023 is pending.

In accordance with the definition cited below, from IEC 61140 *“Protection against electric shock - Common aspects for installations and equipment”*, 3SUN’s PV modules are classified as “Class II”:

“Class II PV modules may have individual and/or system level electrical outputs at hazardous levels of voltage, current and power. The PV modules must provide outputs with basic insulation as basic protection and supplementary insulation as a precaution for fault protection or, alternatively, reinforced insulation that provides both basic and supplementary insulation. Accessible conductive parts must be separated from hazardous live parts by double or reinforced insulation or constructed in such a way as to provide comparable protection. These PV modules are intended for installation where general access by operations and maintenance personnel is anticipated, and can include any kind of PV installation, from a standard roof-top application to large MW-type PV power plants. Most current PV modules fall into this class (See Figure 7 below).”



CLASS OF EQUIPMENT	EQUIPMENT MARKING OR INSTRUCTIONS	CONDITIONS FOR CONNECTION OF THE EQUIPMENT TO THE INSTALLATION	APPLICATION CLASS (IEC 61730-1:2004)	DESCRIPTION FROM IEC 61730-1:2016
Class 0	Only for use in non-conducting environment; or Protected by electrical separation	Non-conducting environment Electrical separation provided for each equipment individually	B	Application in restricted access area
Class I	Marking of the protective bonding terminal with symbol no. 5019 of IEC 60417 [13]  or letters PE, or color combination green/yellow	Connect this terminal to the protective-equipotential bonding of the installation	Special installation measures required	Special installation measures required
Class II	Marking with symbol no. 5172 of IEC 60417 [13] 	No reliance on installation protective measures	A	Application in non-restricted access area
Class III	Marking with symbol no. 5180 of IEC 60417 [13] 	Connect only to SELV or PELV systems	C	No restrictions for protection against electric shock

Figure 7: Application of equipment in a low-voltage installation in accordance with IEC61140 and IEC61730-1: 2016.

Even when a PV module is not connected to a load or an external circuit, voltage can still be produced in presence of light, therefore the use of PPE (**“Personal Protective Equipment”**) including insulation tools such as rubber gloves is mandatory when touching or handling it.

When the PV module is yielding energy, the current flow cannot be stopped by means of a traditional electric switch that is not present.

The only way to interrupt the flow of current is by preventing light from reaching the active areas of the PV module. With relation to the PV modules covered by this manual, due to their bifacial nature, this means the front and the rear of the PV modules themselves.

Under normal conditions, water, snow, or reflective medium could be present around the PV modules, therefore the module is likely to experience conditions that produce higher current and/or voltage than reported at standard test conditions. At this purpose, the values of I_{sc} and V_{oc} , I_{sc} (aBSI) marked in this module need to be calculated at the limit of the operation window of the specific installation site and considering safety factors as indicated in the reference normative (typical safety factor 1.25) when determining voltage and current ratings for components connected to the PV output.

Cable connectors must be kept dry, clean and in good operating conditions. Do not damage and do not apply any change to the connectors as this can cause severe injury or damage to the PV system.

Cable connectors must not be in contact with chemicals such as, but not limited to oil, acetone, alcohol, essential balm, bone-setting liquid, release agents, adhesive and potting materials capable of generating oxime gas, TBP (Tributyl phosphite), cleaning agents, and gasoline.

In case the electrical insulation of the PV module is affected by means of damage to the cable connectors or to the insulation layers in the module itself, the PV module must be safely isolated from the PV system and 3SUN's customer service must be contacted.

3.2. Fire Safety

3SUN's PV modules covered in this document are tested in accordance with the test methods outlined in ANSI/UL 790: 2004, UL 1703: 2016, UL 61730-2: 2020 and the definition included in UL 61730-2: 2020 "Standard for safety PV Module Safety Qualification – Part 2: Requirements for Testing".

3SUN's PV modules covered in this document are tested in accordance with UNI 9177, UNI 8457 (1987) and UNI 8457/A1:1996 - UNI 9174 (1987) and UNI 9174/A1:1996, CLASSE DI REAZIONE AL FUOCO (Fire Rating Class).

For the allowed fire class rating please refer to the datasheet of the specific product variant.

In case of roof installation, please refer to local laws and regulations thus comply with buildings and fire protection requirements of the building. The roof should be made of or covered with fire retardant materials with an appropriate fire protection classification, the PV system designer should ensure that the back of the module and the mounting surface are properly spaced and ventilated. Different roof structures and installation methods will affect the fire performance of buildings. Improper installation may cause fire hazard. Use appropriate protection devices such as fuses, circuit breakers and grounding connectors according to local regulations.

Before installation of the PV modules in a system, the local laws and regulations concerning fire safety and protection must be studied and complied with. 3SUN recommends the adoption of proper module accessories such as fuses, circuit breaker and grounding connectors in accordance with local regulations.

4. Unloading, Transportation and Storage

Prior to installation, the modules must be kept in the original boxes that should be stored in an adequate location to prevent damage as detailed in the following paragraphs. Offloading, movement, and unpacking must follow the procedures indicated in the following sections to avoid any damage to the modules that can compromise their integrity.

4.1. Container Unloading Procedure

As indicated in Section 2.1, 3SUN's standard shipping configuration is: 28 mono-packs loaded in a 40' HQ container as shown in Figure 8 below.

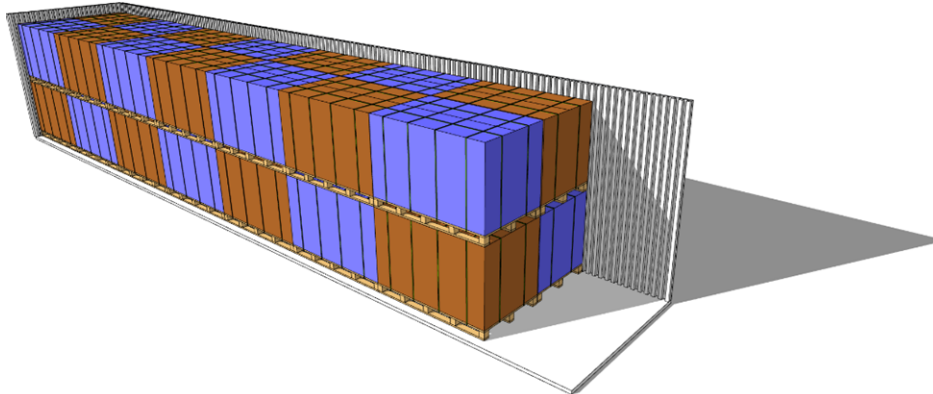

Figure 8: Trailer Maxi container loaded with 3SUN B48 modules

Before unloading, ensure that no damage is present on the wooden pallets and the outer wrapping or cardboards. In case any damage is visible, this must be documented prior to unloading and reported to 3SUN's customer service.

Each mono-pack must be unloaded from the shipping container by means of adequate tools such as forklifts. No more than 1 mono-pack can be lifted at each time. The operators must ensure that after unloading, the mono-packs are placed on a flat surface. Stacking more than two mono-packs on top of each other is not allowed

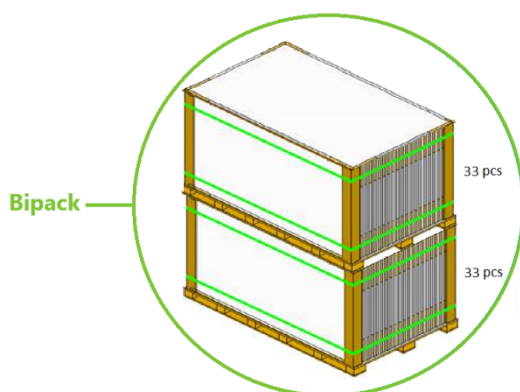

Figure 10: Stacking of two mono-packs is allowed.

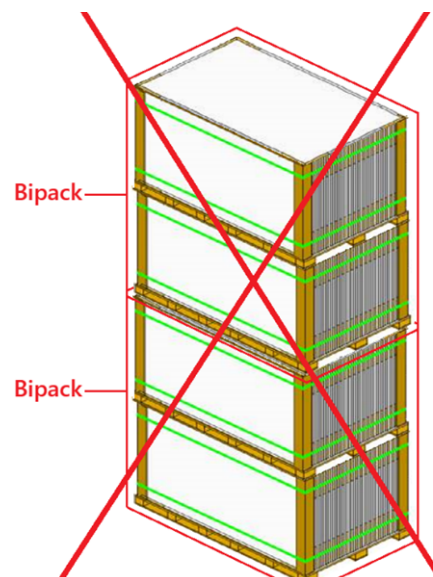

Figure 9: Stacking of three mono-packs is not allowed.

4.2. Storage Conditions

Each single box is wrapped in plastic film, while this provides protection to the products it does not make the packaging waterproof. Prolonged exposure to water or humidity can affect the integrity of the wooden pallet or the cardboard. Therefore mono-packs must be stored in a dry, clean, and ventilated environment. In case mono-packs need to be temporarily stored outdoors, adequate protection from water needs to be adopted. In case bi-packs are foreseen to be moved to a secondary storage location then the original packaging must not be damaged or removed. The temperature of the storage location must be within -20°C and +50°C.

4.3. Secondary Transportation

Do not place heavy objects on the mono-packs during transportation. Improper transportation can damage the PV modules and invalidate the warranty.

Preferably the mono-pack is disassembled only at the final storage location where top and bottom boxes are unstacked.

The original packaging, including the straps, must not be removed if the mono-packs are meant to be transported to a secondary storage location. The single boxes must be transported one at a time and not stacked. Only once they have reached their designated storage location in the warehouse is it permitted to stack up to two single boxes (See Figure 11).

Transportation by land, sea or air is allowed if the original packaging is still present. The stacked mono-packs or the individual unstacked mono-packs must be secured adequately during transportation to prevent tumbling or shifting that can cause damage to the PV modules.

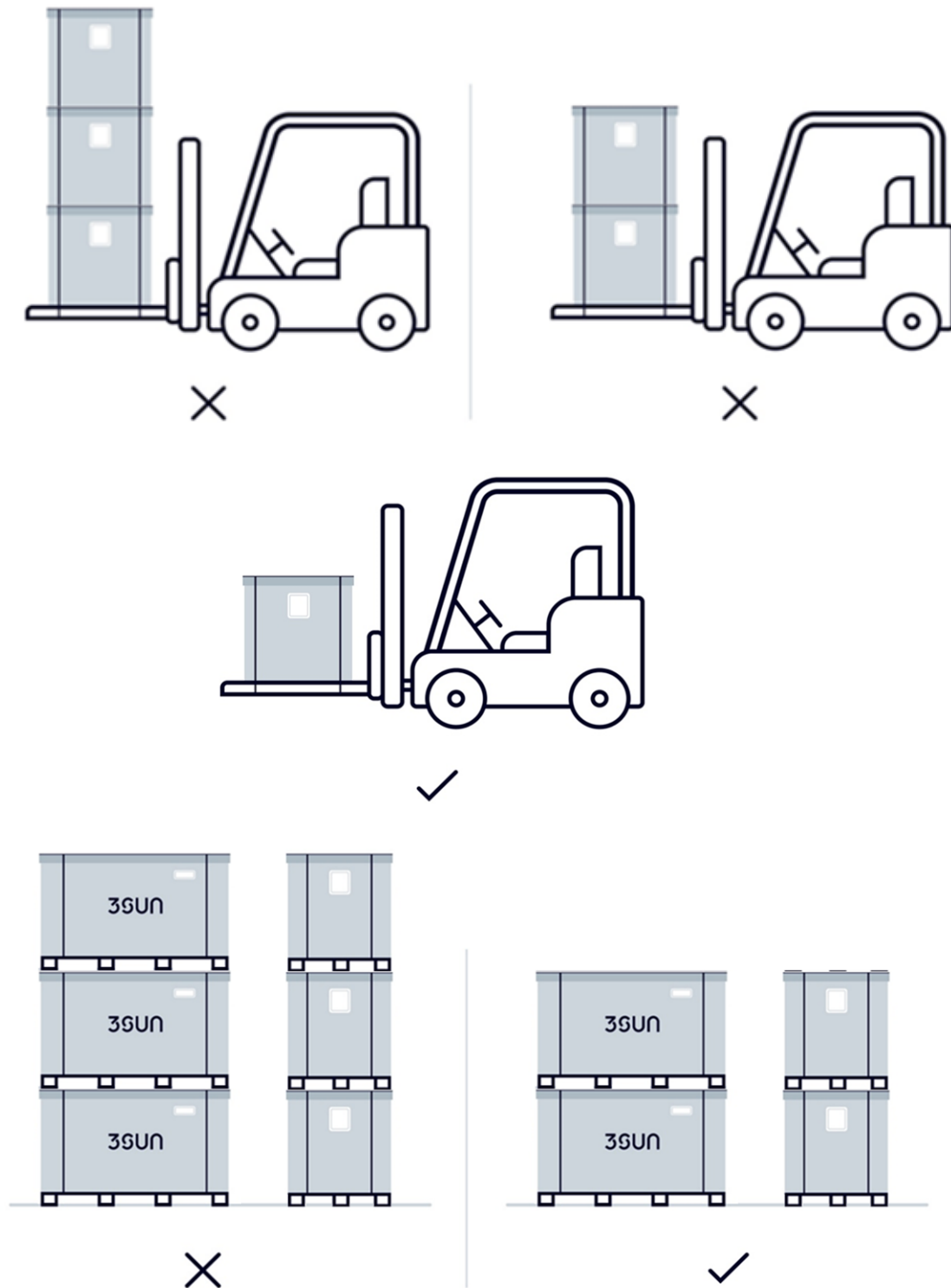

Figure 11: It is not permitted to stack more than two single boxes

4.4. Warnings

Follow these instructions:

- Prior to unpacking, carefully read this installation manual.
- The pack must be opened in proximity to the installation site where PV modules can be moved by hand to the mounting location over a short distance.
- The top box of the bi-pack must be unstacked with adequate tools such as forklifts.
- At least two people are necessary to lift and move a single PV module.
- The PV module must not be lifted or dragged from the cables or the junction boxes.
- Pay particular attention when unpacking during windy days.
- While unpacking the PV modules, adequate measures to prevent them from falling must be adopted.
- After unstacking, one of the two boxes can be used as a lateral support for the other. If the other box is not available, use any other support that is sufficiently tall and heavy, or a structure such as a pillar, a wall, etc.
- Gloves must be worn during unpacking and handling of the PV modules to prevent injury and leaving fingerprints on the glass.
- Once PV modules are unpacked, they cannot be stored and must be installed in the PV system.

4.5. Unpacking Sequence

1. Remove and safely store the shipment datasheet attached to the exterior wrapping of the mono-pack.
2. Remove the outer mono-pack plastic wrapping and dispose of it accordingly.
3. Unstack the top box by using adequate tools, such as a forklift, and place it alongside the bottom box so that the two pallets are aligned over the long end (Figure 12).

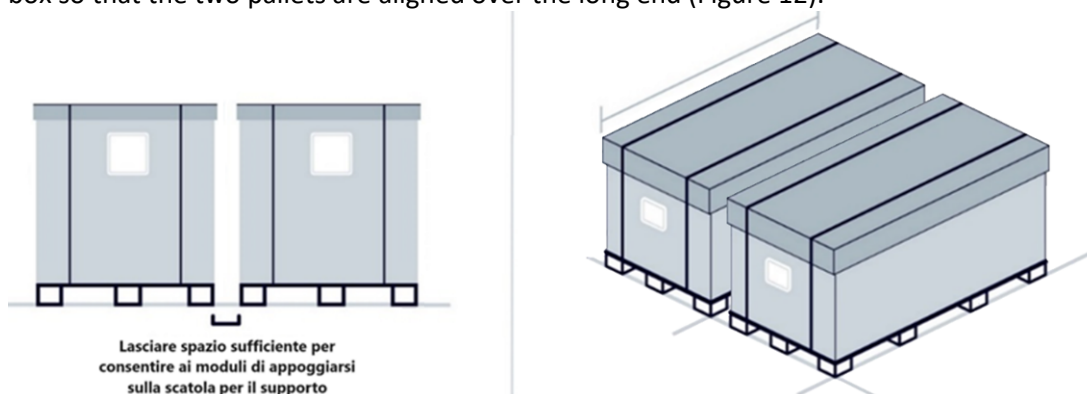

Figure 12: Boxes correct alignment.

4. The two pallets need to be distanced sufficiently so that in the following steps the PV modules in the unpacked box can safely lean against the box placed beside for support.
5. Always start the unpacking process from the **bottom box**:
 - a) Cut the outer box straps (Figure 13).
 - b) Remove the box cardboard cap and then the perimetral cardboard box (Figure 14).
 - c) Cut nine of the internal straps. First cut the horizontal straps #1, #2, #3, #4 (Figure 15), then cut the vertical straps #5, #6, #7, #8, #9, in any order. Do not cut strap #10 until step e).
 - d) Gently push the PV modules so that they can safely lean against the box placed beside for support during step 4 (Figure 16).

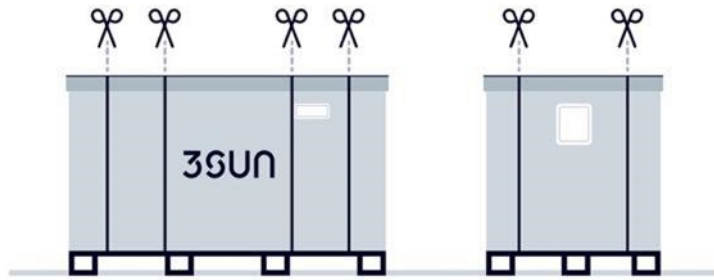

Figure 13: Box internal straps removal order.

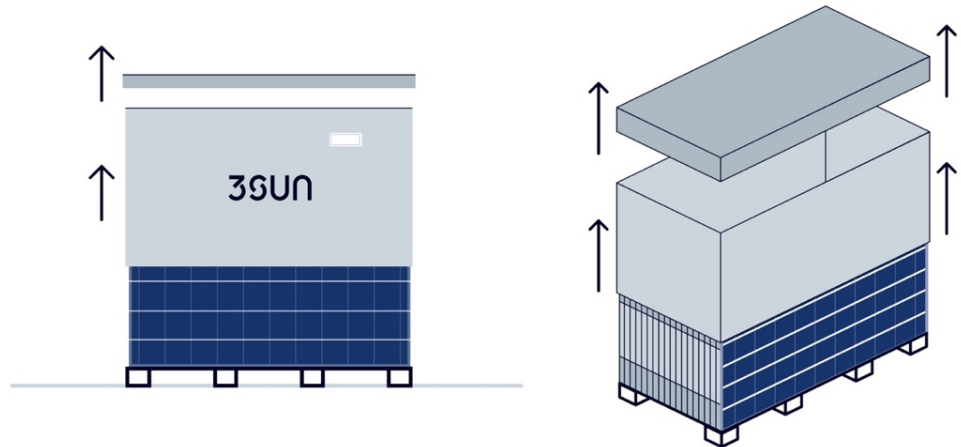

Figure 14: Removal of perimeter cardboard box and box top.

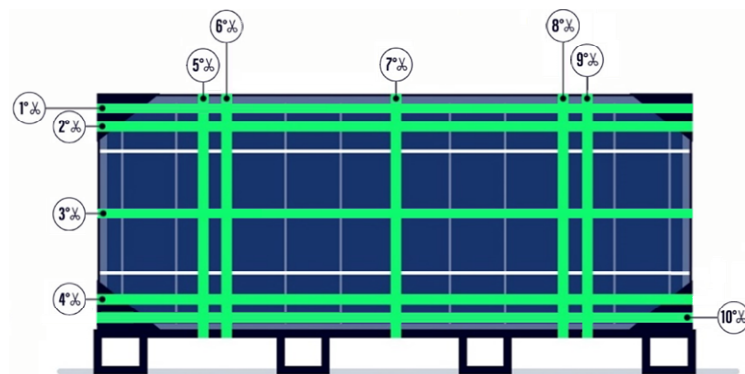

Figure 15: Positions of internal straps.

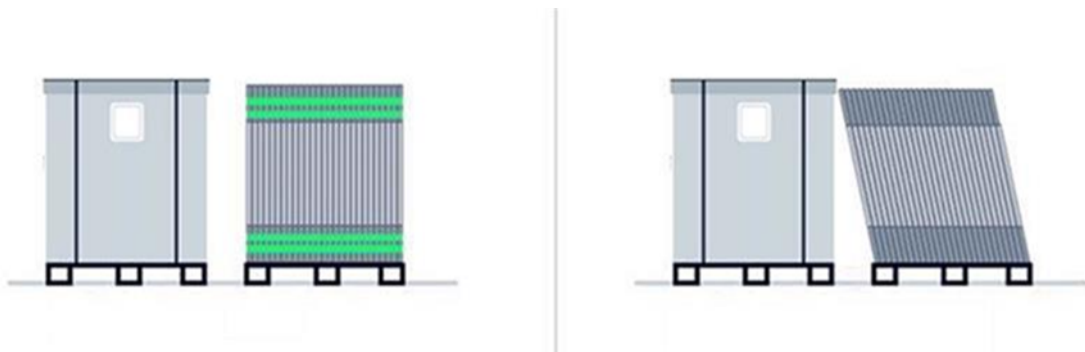

Figure 16: Tilt of the modules leaning on the box for support

- e) Cut strap #10.
- f) One person at each side of the box (two in total) is needed to extract PV modules from the bottom box.
- g) PV Modules must be grabbed from the aluminum frame with two hands (Figure 17).

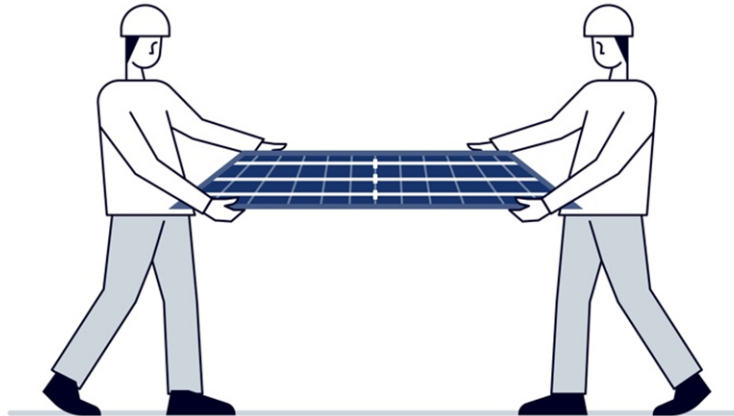

Figure 17: Module handling.

- h) Prior to leaving the unpacked box unattended, ensure that the PV modules still in the box have adequate lateral support from the box placed beside or by other means to prevent them from falling.
- i) Install the PV module on the chosen mounting structure with the instructions indicated in Section 5.2.

4.6. Handling Instructions

A sheet containing the handling instructions is attached to each mono-pack and depicts in a graphic way the steps one must follow when handling each mono-pack. Table 4 below includes additional explanations for each step.

Table 4: Handling instructions

	<p>Before handling the mono-pack scan the QR code at the bottom of the Shipment Data Sheet to access the installation manual and warranty note</p>
	<p>Handle with care, avoid dropping the mono-pack to the ground</p>

	<p>Be sure to use forklifts that are suited to handle the weight of the mono-pack</p>
	<p>To ensure the stability of the mono-pack and safeguard its integrity, the mono-pack must be positioned on horizontal and regular surfaces</p>
	<p>To avoid damaging the bottom of the pallet with the fork tips, use a forklift with forks longer than the pallet</p>
	<p>Due to the weight of the load, the pallet could fall off or break if not supported appropriately. Therefore the forklift forks must be set to the maximum width that ensures stability; furthermore, all movements must take place at a maximum speed of 5 km/h.</p>
	<p>Due to the high inertia of the bi-pack, only straight movements are permitted with a maximum speed of 5 km/h. If you need to change direction, slow down further.</p>
	<p>Do not load further with a third mono-pack, as this can damage the PV modules.</p>

5. Installation Conditions

The installation of PV modules in a system must be conducted in compliance with the local safety regulations and the instructions included in this manual.

5.1. Installation Safety

When operating on a PV system follow the following recommendations:

- Always wear dry insulation protective equipment such as: insulated tools, headgear, insulated gloves, belts, and safety shoes (with rubber soles).
- DO NOT work alone.
- Keep the photovoltaic module packed in the box until installation.
- DO NOT install modules in rainy, snowy, windy or any other adverse weather conditions.
- DO NOT carry out any work if the PV module terminals are wet.
- Keep the PV module connectors dry and clean during installation.
- DO NOT stand on the module glass during installation.
- Use an opaque material to completely cover the surface of the PV module during its installation and wiring.
- DO NOT disconnect the connector if the system circuit is connected to a load.

5.2. Operating Window and Applications

5.2.1. Site Selection and Ambient Conditions

PV modules can have an operating temperature ranging from -40°C (-40°F) to 70°C ($+158^{\circ}\text{F}$). This temperature range must be ensured for the 98th percentile of the module operating life (installation in extreme climate conditions, like desert or sever climate, could be higher, i.e. a couple of weeks). Additional structural measures must be taken to keep the operating temperature within the range specified above. Possible measures to reduce the operating temperature of the PV modules would be: enlargement of the rear ventilation space; increasing the air flow rate in the rear ventilation space (actively controlled if necessary); cooling system in the rear ventilation space.

The PV module site installation must not exceed the altitude of 2000m asl.

PV modules are designed and certified to withstand front (snow) and rear (wind) load levels based on the approved installation method(s) and configurations shown in Section 5.3. PV modules can be installed in sites and configurations where these loads won't be exceeded. Moreover, external or otherwise artificially concentrated sunlight shall not be directed onto the front or back face of the PV module. Moreover, the PV module is tested according to IEC 61701:2020 "Salt mist corrosion testing" – Severity Level 6 (Certification in progress) and to IEC 62716:2013 "Ammonia corrosion testing" (Certification in progress).

If during its lifetime the PV module experiences operating conditions that go beyond what is defined in this manual, the module datasheet and the testing conditions of the certification process, the warranty will be void.

5.2.2. Applications and System Recommendations

The PV module is designed, tested, and certified for traditional onshore applications such as in strings mounted on fixed or tracking structures.

The PV modules of 3SUN's B48 family are designed, tested, and certified to have the front of the module (Figure 18) exposed to direct sunlight. Due to their bifacial nature, the PV modules can yield energy from the light that reaches the rear glass; this light has predominantly a diffuse component that depends on the overall site irradiation, the albedo factor, and the view factor. The B48 family PV

modules can also be installed in monofacial applications such as on rails on sloped roofs where a minimum amount, if any, of light reaches the rear of the module. However, for monofacial applications, an installation slope inferior to 5 degrees may significantly impact module cleanliness.

Shading of PV modules during operation from adjacent rows of PV modules or obstacles such as trees, vegetation, or constructions, must be minimized. Prolonged partial shading of a module must be avoided.

Use of the PV modules covered by this document for applications or operating conditions beyond what indicated in Section 5.1 must be validated with 3SUN's customer service to confirm the validity of the product and performance warranties.

5.3. Mechanical Installation and Approved Mounting Configurations



Figure 18: B48 front side of the module.

PV modules can be connected to mounting systems using bolts, clamps, rivets, or custom systems. The installation method and mounting system for 3SUN's modules must be chosen compatibly with the specifications of the following paragraphs.

3SUN continuously tests the performance of its PV modules in different configurations. As the tests are completed, additional approved mounting methods with their approved operating loads will be added to Section 5.2.2 in new revisions of this manual.

In case more information is needed concerning mounting configurations not yet included in Section 5.2.2 please contact 3SUN's customer service.

5.3.1. General Requirements and Warnings

- The maximum loads indicated on the module datasheet are specific to certain mounting techniques and configurations as indicated in Section 5.2.2.
- The maximum loads indicated in Section 5.2.2 might be limited by an improper choice of mounting components and mounting configuration.
- Ensure that the mounting systems and tools are tested, in compliance with the applicable norms and are compatible with the loads expected by the system during its lifetime.

- PV modules must be firmly fixed on the mounting structures at all times.
- PV modules must be installed in such a way that accommodates thermal expansion experienced by the frames or structures throughout the year.
- The mechanical loads indicated in the following sections are “test loads”. According to the IEC61215 - 2021, when calculating the corresponding maximum design load, a division by 1.5 safety factor must be considered.
- The values in Section 5.3.2, Section 5.3.3, and Section 5.3.4 are either certified or derived from internal testing. Unless specifically noted, they should be assumed to be the result of internal tests.
- PV modules can be installed in both vertical (portrait) or horizontal (landscape) orientation.
- Ensure that regardless of the mounting orientation the drainage hole present on the frame is not blocked.
- Sufficient clearance between the lower edge of the modules and the installation surface must be ensured in such a way that the lower end of the PV module is never covered by snow.
- In the case of roof installation, ensure that the roof is suitable for the purpose.

5.3.2. Clamps Installation

PV Modules can be mounted on systems by means of mounting clamps. The clamps must be installed to the roof mounting interface, typically a rail or a ballast, and to the frame of the module as shown in Figure 19. The clamp must not be in contact with the glass and must not deform the frame of the module. The interface of the clamp and the front side of the frame must be flat and smooth to avoid damage to the frame and the PV module. The clamp must not project a shadow on the glass.

The clamp must have a minimum length of 50 mm (1.97 inch) and a minimum thickness of 4 mm (0.16 inch) and must be made of aluminum. The clamp must overlap the module frame by at least 8 mm (0.32 in) but no more than 12 mm (0.47 in).

3SUN recommends using clamps that attach to the mounting rails with a fixing bolt of at least M8 dimension.

While mounting a clamp, excess torque force could damage the module frame while insufficient torque force could result in an instable connection of the PV module to the mounting structure. The appropriate torque range lie on 15-20 Nm (133-180 lbf.in.). We recommend the use of an appropriate dynamometric wrench to measure the effective force applied. The adequate force depends on the specifications of the clamp in use. In case of need, contact 3SUN’s customer service.

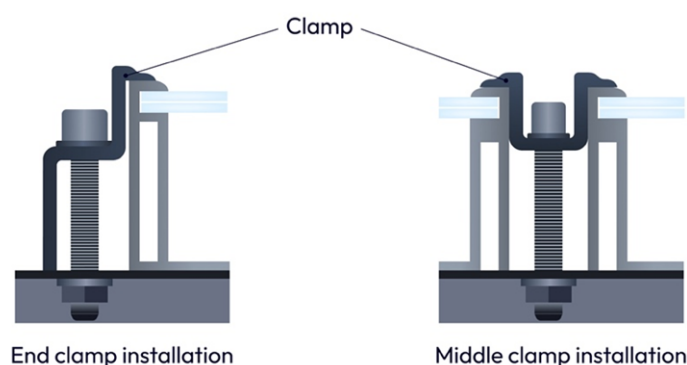
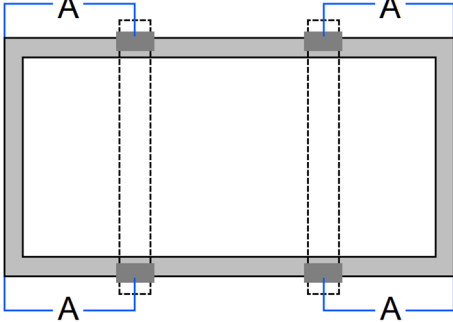
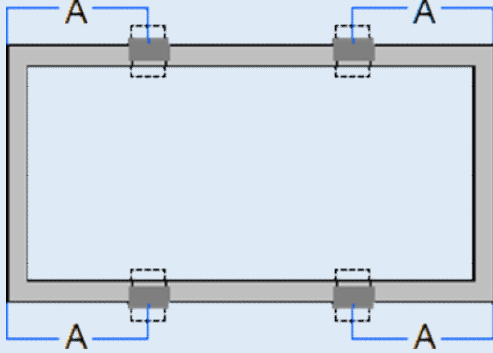
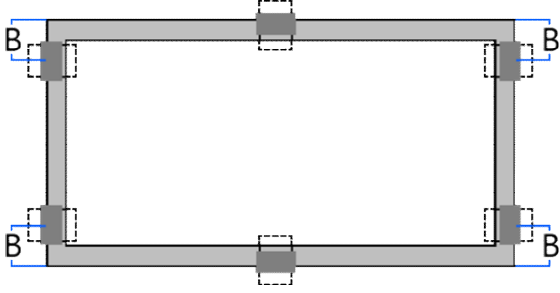

Figure 19: Example of clamp installation.

The approved maximum loads and the positioning of the clamps in the different configurations is summarized in Table 5 below.

Table 5: Installation configuration and maximum loads with clamps.

Mounting Method	Description	Approved Loads
<p>Configuration C1:</p> <p>Perpendicular bars</p> <p>4 clamps</p>	 <p>Use 4 clamps on the long side. Mounting rails run perpendicular to the long side frame.</p>	<p>A = (290 – 350) mm</p> <p>Certified Test load: Uplift load ≤ 2400 Pa Downforce load ≤ 5400 Pa</p> <p>Certified Design load: Uplift load ≤ 1600 Pa Downforce load ≤ 3600 Pa</p>
<p>Configuration C3:</p> <p>4 floating supports, no rails</p> <p>4 clamps</p>	 <p>4 clamps on the long side, no rails</p>	<p>A = (290 - 350) mm</p> <p>Internal test load: (not certified by third parties) Uplift load ≤ 1800 Pa Downforce load ≤ 3000 Pa</p> <p>Design load for: Uplift load ≤ 1200 Pa Downforce load ≤ 2000 Pa</p>
<p>Configuration C4:</p> <p>6 floating supports, no rails</p> <p>6 clamps</p>	 <p>4 clamps on short side and 2 on long side, no rail</p>	<p>B= (0 - 200) mm</p> <p>Internal test load: (not certified by third parties) Uplift load ≤ 2600 Pa Downforce load ≤ 3000 Pa</p> <p>Design load for: Uplift load ≤ 1700 Pa Downforce load ≤ 2000 Pa</p>

<p>Configuration C5:</p> <p>4 floating supports, no rails</p> <p>4 clamps</p>	<p>4 clamps on short side, no rail</p>	<p>B= (0 - 300) mm</p> <p>Internal test load: (not certified by third parties)</p> <p>Uplift load ≤ 1500 Pa</p> <p>Downforce load ≤ 1500 Pa</p> <p>Design load for:</p> <p>Uplift load ≤ 1000 Pa</p> <p>Downforce load ≤ 1000 Pa</p>
		<p>B= (150 - 250) mm</p> <p>Internal test load: (not certified by third parties)</p> <p>Uplift load ≤ 1600 Pa</p> <p>Downforce load ≤ 2000 Pa</p> <p>Design load for:</p> <p>Uplift load ≤ 1000 Pa</p> <p>Downforce load ≤ 1300 Pa</p>

Note: the configuration with perpendicular bars will affect the yield of energy from the rear in bifacial applications.

5.3.3. Bolt or Rivet Installation

The frame of the PV module has a series of mounting holes that depend on the module variant (see Table 6) as shown in Figure 21. These allow different mounting positions by means of rivets or bolts.

3SUN recommends the use of corrosion resistant mounting components, such as stainless steel.

For the holes in the 400 mm 3SUN recommends the use of M6 bolts while for the holes at 1400 mm we recommend the use of M8 bolts. We advise to use two flat washers for each bolt, one spring washer and one nut and tighten them to a torque of 16-20 Nm (140-180 lbf.in.). The yield strength of bolts and nuts must not be less than 450 MPa.

Table 6: Mounting hole positions by product variant

Hole	400 mm φ7*10mm	1400 mm Φ9*14mm
Product Variant		
3SHBGA-AF	✓	✓
3SHBGA-CF	✓	✓

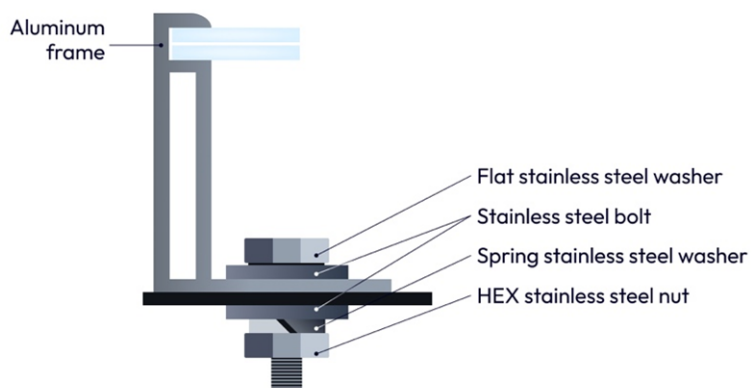

Figure 20: PV module installed with bolt fitting method.

The approved maximum loads for screw installations in the different configurations is summarized in Table 7 below.

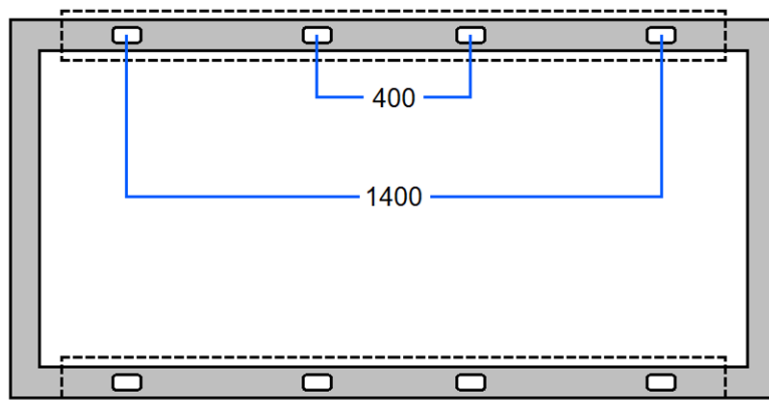
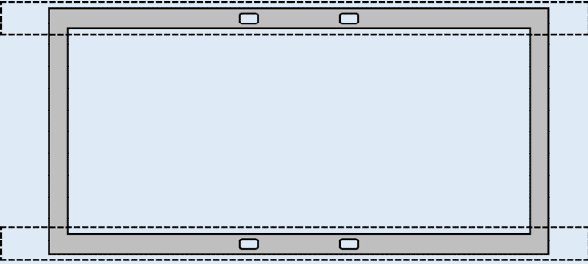
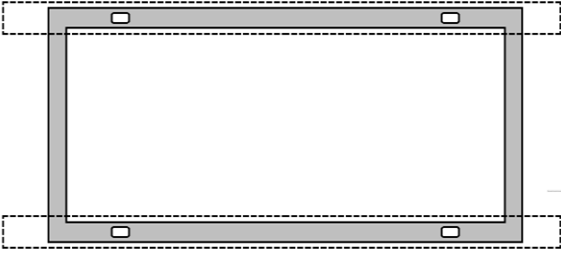

Figure 21: Frame mounting hole position.

Table 7 installation configuration and maximum loads with bolts and rivets

Mounting Method	Description	Approved Loads
<p>Configuration S1:</p> <p>Perpendicular bars</p> <p>4 bolts</p>	<p>Mounting rails run perpendicular to the long side frame.</p> <p>Distance between mounting holes is 1400mm.</p>	<p>Internal test load: (not certified by third parties)</p> <p>Uplift load \leq 2400 Pa</p> <p>Downforce load \leq 5400 Pa</p> <p>Design Load:</p> <p>Uplift load \leq 1600 Pa</p> <p>Downforce load \leq 3600 Pa</p>

<p>Configuration S2:</p> <p>Parallel bars</p> <p>4 bolts</p>	 <p>Mounting rails run parallel to the long side frame. Mounting holes 400mm.</p>	<p>Internal test: (not certified by third parties)</p> <p>Uplift load \leq 2400 Pa Downforce load \leq 2400 Pa</p> <p>Design Load:</p> <p>Uplift load \leq 1600 Pa Downforce load \leq 1600 Pa</p>
<p>Configuration S3:</p> <p>Parallel bars</p> <p>4 bolts</p>	 <p>Mounting rails run parallel to the long side frame. Distance between mounting holes is 1400mm.</p>	<p>Internal test: (not certified by third parties)</p> <p>Uplift load \leq 2400 Pa Downforce load \leq 3600 Pa</p> <p>Design Load:</p> <p>Uplift load \leq 1600 Pa Downforce load \leq 2400 Pa</p>

5.3.4. Installation Configuration Summary

Table 8 summarize the mechanical loads for the considered installation configurations, the values are either certified or derived from internal testing as specified in table below (safety factor 1.5).

Table 8: Installation Configuration Summary

	Configuration	Test Load		Design Load		Note	
		Uplift [Pa]	Downforce [Pa]	Uplift [Pa]	Downforce [Pa]		
Clamps	Certified Test (certified by third parties)						
	C1	4 clamps, rail perpendicular to long side Certified A =290 – 350 Suggested A=250 – 310	2400	5400	1600	3600	clamp \geq 50 mm; Thickness \geq 3mm; Bolt M8; 15-20Nm;
	Internal Test (not certified by third parties)						
	C1	4 clamps, rail perpendicular to long side (A =250 – 350)	2400	5400	1600	3600	clamp \geq 50 mm; Thickness \geq 3mm; Bolt M8; 15-20Nm;
	C3	4 clamps, 4 floating supports, no rails (A =250 – 350)	1800	3000	1200	2000	clamp \geq 50 mm; Thickness \geq 3mm; Bolt M8; 15-20Nm;
C4	4 clamps on short side and 2 on long side, no rails (B =0 – 200)	2600	3000	1700	2000	clamp \geq 50 mm; Thickness \geq 3mm; Bolt M8; 15-20Nm;	
C5	4 clamps on short, no rails (B =0 – 200)	1500	1500	1000	1000	clamp \geq 50 mm; Thickness \geq 3mm; Bolt M8; 15-20Nm;	
Bolts or Rivets	S1	Mounting rails Perpendicular to long side (holes distance 1400 mm)	2400	5400	1600	3600	M8; 16-20Nm
	S2	Mounting rails parallel to long side frame (holes distance 400 mm)	2400	2400	1600	1600	M6; 16-20Nm
	S3	Mounting rails Parallel to long side (holes distance 1400 mm)	2400	3600	1600	2400	M8; 16-20Nm

In case details for configurations not included in Section 5.2 are needed please contact 3SUN's customer service.

5.4. Electrical Installation

5.4.1. Electrical Performance

The electrical performance of the PV module indicated on the product datasheet, is reported with an uncertainty of +/-5% or better and measured at Standard Test Conditions (STC): 1000 W/m² Irradiance, cell temperature of 25 °C and AM1.5 spectrum. PV modules can only be connected with other PV modules of the same type in strings or sets of strings in series or in parallel as shown in Figure 22. **L'origine riferimento non è stata trovata..** Strings length must be designed in accordance with the voltage operating range of the inverter and must consist of PV modules of the same Power Bin. When the PV modules are connected in series the string output voltage is the sum of individual module voltages. Instead, in parallel connection, the current output is the sum of the individual module currents. Connecting PV modules with large discrepancies in electrical parameters must be avoided to maximize the potential of the PV system.

The system layout must be defined in accordance with the local regulations and the operating limits of the PV modules and other elements in the Balance of System (BOS) such as inverters. To dimension the module string length and the series or parallel connections of strings to the inverter the designer must consider the highest open circuit voltage that the module and consequently the string can reach during operating conditions. The open circuit voltage is a function of the module temperature which depends on ambient temperature and irradiance; thus, it varies across the day and year and it is site specific.

More in details, the maximum number of installable series modules in a string N_s must respect the following equation:

$$N_s < V_{DC}/V_{OC,MAX}$$

where V_{DC} is the maximum system voltage which for the 3SUN module is rated for a maximum of 1500V as indicated in the product datasheet, while $V_{OC,MAX}$ is the maximum open circuit voltage calculated at the minimum temperature reachable in the installation site as showed in the following equation.

$$V_{OC,MAX} = V_{OC,STC} \cdot [1 - \beta(25 - T_{cell,min})]$$

where $V_{OC,STC}$ is the open circuit voltage at STC, β is the open circuit voltage temperature coefficient (%/°C); and $T_{cell,min}$ (°C) is the minimum cell temperature reachable at the installation site.

The maximum allowed number of strings in parallel N_p must respect the following equation:

$$N_p < I_{DC,max}/(1.25 \cdot I_{SC})$$

where $I_{DC,max}$ is the maximum DC current permitted by the MPPT channel of the inverter, and I_{SC} is the module short circuit current (if the module is installed in a manner to exploit its bi-faciality, in Bifacial Nameplate Irradiance BNPI conditions, $I_{SC,BNPI}$ should be considered instead).

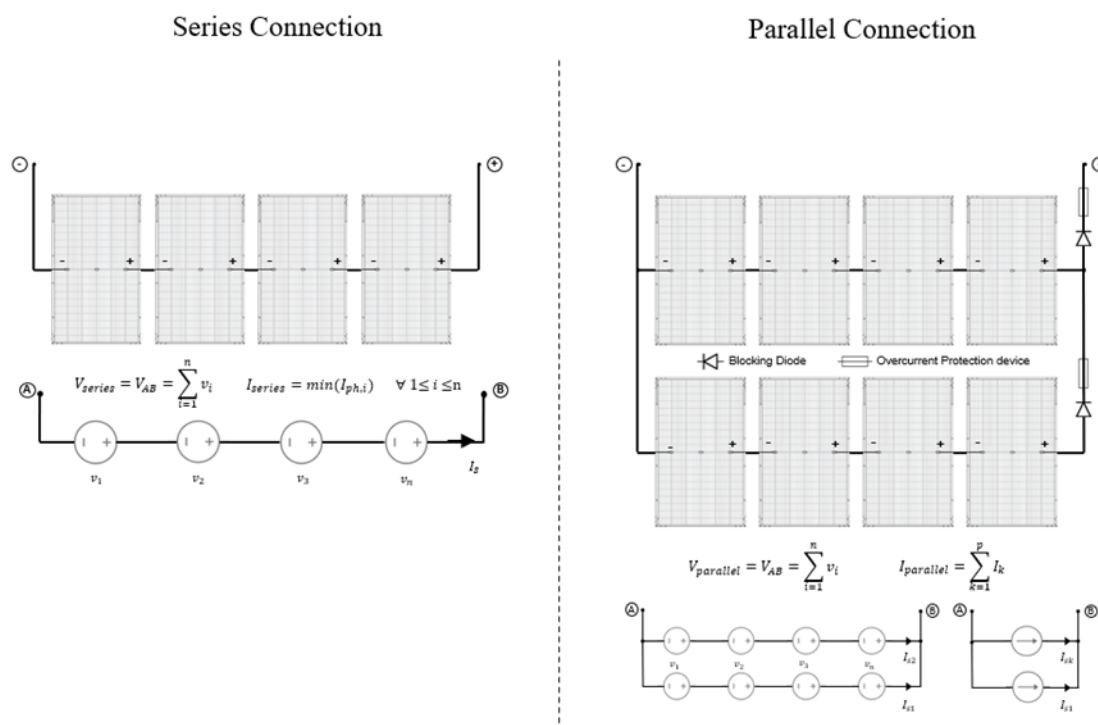

Figure 22: Series Connection and Parallel Connection Circuit Diagram.

5.4.2. String Interconnection

In PV system, PV modules are typically interconnected to each other in strings and then to an inverter. The most common interconnection techniques are known as Daisy-Chain and Leapfrog.

5.4.2.1 Portrait: Daisy-Chain Technique

With this technique each module is connected in series to the adjacent one to form a string. At the end of the string a return wire is connected and routed to the inverter. This technique can be adopted with PV modules either in a portrait orientation (Figure 23) or landscape orientation based on the length of the cables.

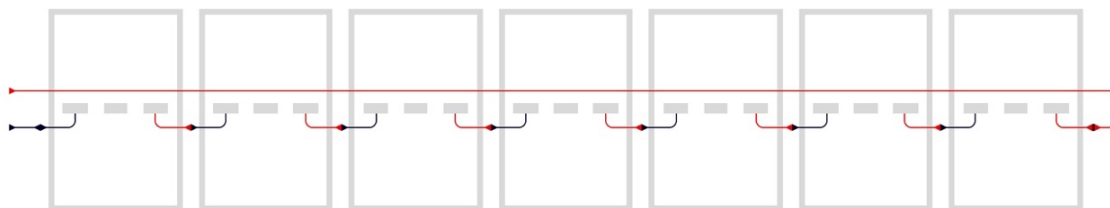

Daisy-Chain Wiring

Figure 23: Daisy-Chain interconnection for portrait modules.

5.4.2.2 Portrait: Leapfrog Technique

With the leapfrog technique each PV module is connected in series to the second next one (skipping the adjacent one) to form a string. Once the end of the row is reached, the series continues with the same approach backwards towards the beginning of the array. With this technique the need for a return cable falls although the cables of the PV modules must be longer. This technique can be adopted with PV modules either in portrait orientation (Figure 24) or landscape orientation based on the length of the cables.

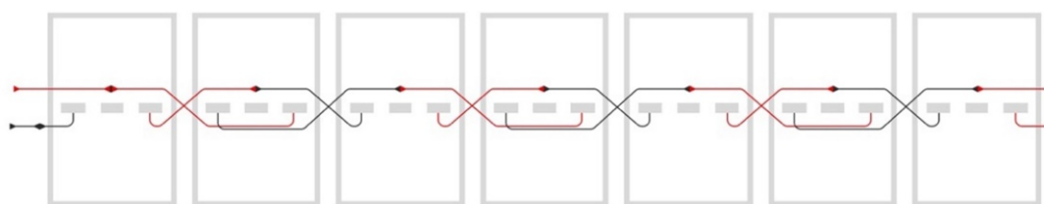

Leapfrog Wiring

Figure 24: Leapfrog interconnection for portrait modules.

5.4.2.3 Landscape: Daisy-Chain Technique

The proper methodology for Landscape Daisy Chain installation is illustrated in (Figure 25).

Front Side: Alternate Label and Module Position



Back Side: Landscape Wiring

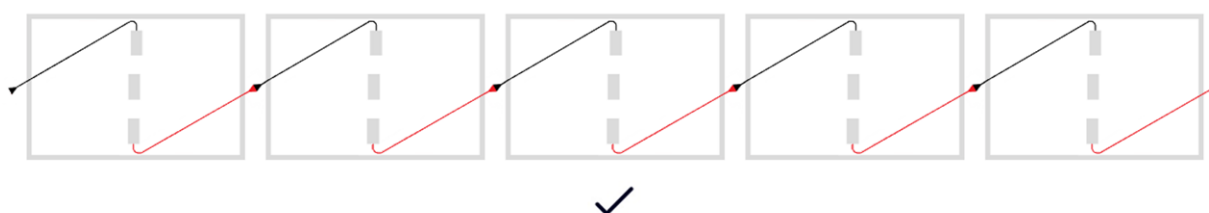

Figure 25: Daisy-Chain positioning and interconnection for landscape configuration– in case of 1400mm cable

For sake of clarity, (Figure 26) provides an example of the top right label seen from the front glass.



Figure 26: Example of permanent label at the top-right of the front glass

Table 9: Compatibility of 3SUN PV modules with interconnection techniques.

Product Variant	Cable length	Daisy-Chain		Leapfrog	
		Portrait	Landscape	Portrait	Landscape
3SHBGA-AF	1400 mm	✓	✓	✓	
3SHBGA-CD	1400 mm	✓	✓	✓	

5.4.3. Cables and Connectors

All electrical connections and wiring used to interconnect the modules must be appropriately sized for the intended application, in compliance with electrical codes and applicable regulations.

3SUN PV modules have a positive and negative cable equipped with QC Solar or Stäubli connectors as specified in Table 10. The minimum bending radius of cables must be 43mm (1.69in). The section of the conductive material inside the cables is 4 mm².

Table 10 Mounted connector types per PV product variant

Product Variant	Supplier	Mounted Connector
3SHBGA-AF	Stäubli	MC4 EVO2: PV-KST4 – EVO2A/XY (Male) PV-KBT4–EVO2A/XY (Female)
3SHBGA-CD	Stäubli	MC4 EVO2: PV-KST4 – EVO2A/XY (Male) PV-KBT4–EVO2A/XY (Female)

The connectors of the Junction Boxes used on our PV modules are designed for cables with a minimum external diameter of 5.6 mm and a maximum external diameter of 6.8 mm.

When wiring the PV modules in series, the positive terminal of one PV module must be connected to the negative terminal of the next module and so on.

Before loading the system, the installer must verify that wiring is correct by measuring the string open circuit voltage and short circuit current.

Improper interconnection can cause electric arc and electric shock. Ensure that every connection is secure and that the connectors are fully locked.

Do not match 3SUN connectors with cables or terminals that use different connectors (model or brand).

During the installation and wiring procedure, appropriate measures to prevent humidity or dust from entering the connectors must be taken.

While cables and connectors are UV resistant and IP68 rated, when connected and locked, they must be tied and secured to the mounting structure or the PV module frame to avoid contact with water exposure to direct sunlight, and unwanted access to animals. Full submersion underwater must be avoided at all times. Physical damage to the cables and connectors must be avoided at any phase, from unpacking to installation and operation.

5.4.4. Bypass Diode

Each junction box of the PV modules contains bypass diodes that are activated to prevent current from passing in certain sections of the PV module in case of shading or in presence of a hot spot. The bypass diodes mitigate over-heating and the loss of PV module performance but are not an overcurrent protection device that can be instead installed at a string level.

The bypass diodes installed in the 3SUN module is provided by QC Solar (QCM6045 [35A] and QCM5045B [30A]). If the bypass diode is faulty or suspected to be faulty, the installer or the technician must contact 3SUN's customer service.

The lid of the junction box must not be opened without explicit authorization by 3SUN's customer service.

5.4.5. Bonding and Grounding

The PV module frame is made of an anodized corrosion resistant aluminum alloy and has the primary function of providing mechanical rigidity to the PV module. To protect the modules and prevent injury to people, the frame must be bonded and grounded appropriately according to the local safety regulation.

For a ground connection multiple bonding/grounding holes with a diameter of \varnothing 4.3mm are also available on the aluminum frame and are indicated by the earthing symbol. The center line of the

earthing mark, also located on the edge of the PV module's rear frame, overlaps that of the bonding hole.

These holes are to be used solely for grounding. No additional bonding/grounding holes can be made.

Bonding/grounding devices such as clamps and wires must be provided from qualified suppliers of electrical components and the connection must be validated by qualified electricians. The recommended torque of the copper wire used for bonding is approximately 2.3 Nm, with a copper wire of 4mm². Copper wires must not be pressed during installation to prevent damage.

If a frame mounting hole is not used for installation of the PV module to the structure, it can be used for bonding.

6. PV Module maintenance

Inspection and maintenance of the PV modules are mandatory other than necessary to preserve their functionality and safety. The following section contains 3SUN's recommendations for a correct PV module maintenance. We remind you that non-compliance with the maintenance recommendations below voids manufacturer's duties and obligations under 3SUN's Warranty Terms and Conditions. Therefore, 3SUN won't be deemed responsible for damages and injuries provoked by errors and failures in conducting maintenance operations.

6.1. Module Visual Inspection and Replacement

Periodical visual inspection must be conducted to identify damages to the PV modules. 3SUN recommends conducting inspections at least every 6 months, after severe weather phenomena or when the PV system is not performing as expected.

Electrical, grounding, and mechanical connections must be checked to ensure their functionality is preserved, in particular:

- Mechanical and electrical connections must be clean, without any sign of damage or rust;
- All cables must be checked to ensure they are safely connected;
- Mounting parts must be tight, frames and mounting rails must be well connected;
- The isolation silicone around the junction box must be intact.

The front and rear of the PV module must be inspected to ensure no stains or foreign bodies are attached to the module surface.

Evidence of hotspots, broken or cracked front or rear glass, bent or deformed frames, damaged connectors, cables, or junction boxes represent a safety risk for people and the integrity of the PV system. In case any of these damages are observed on a PV module, this PV module must be isolated and safely removed. The damage must be documented and 3SUN's customer service must be informed.

All PV system maintenance procedures (including but not limited to PV modules, inverters, rectifiers, or batteries) must be followed to safely isolate and then remove a damaged PV module. These procedures must include instructions on how to un-load and isolate a system or subsystem to conduct maintenance safely and indicate the required personal protective equipment. Non-compliance with the procedures when conducting maintenance can cause life-threatening injury such as electric shock and burns. Maintenance must be conducted by qualified personnel with adequate level of experience.

A PV module generates voltage in presence of light also when disconnected from a load. When possible, the maintenance on PV modules must be conducted in absence of light at night or after covering the front and rear of the module with adequate material that does not let light through.

Damaged PV modules must be replaced with PV modules of the same type (model and performance), when possible.

Safety devices such as cut resistant insulation gloves are mandatory when handling damaged PV modules, wires, and connectors. Exposed wires and connectors must not be touched directly.

The PV modules cannot be repaired on-site without prior authorization from 3SUN's customer service.

6.2. Cleaning

The presence of dust, dirt or stains on the module glass will affect its electrical performance. 3SUN recommends cleaning the module glass once a year, depending on the site conditions. PV Modules installed at sites with dry conditions or heavy soiling levels might require more regular cleaning.

Cleaning of PV modules must be conducted considering the following instructions:

- Always conduct a visual inspection prior to cleaning to ensure there are no safety risks.
- If the glass of a module is broken, wires are exposed or the aluminum frame is bent, do not clean the PV module.
- Disconnect the string or subsystem being cleaned in accordance with the PV system maintenance procedure.
- Water with a high mineral level may leave deposits on the glass surface and damage the anti-reflecting coating of the glass, therefore neutral water must be used for cleaning.
- Do not use abrasive materials under any circumstances as these might damage the integrity of the module.
- Avoid cleaning methods that employ rotating brushes, as they could create micro-cracks in the PV modules and affect module performance.
- Dirt or soiling must never be scraped when dry, this will cause micro-scratches on the glass surface and affect the module performance.
- 3SUN recommends cleaning the PV modules, during the early morning or the late afternoon, when solar radiation is low and the module temperature is cooler, to reduce the risk of electric shock.

At the end of the cleaning procedure, the PV modules must appear clean, and spotless with no accumulated dust and no scratches or cracks on the glass or frame surface.

6.3. Troubleshooting

In case the PV module is malfunctioning or underperforming, first perform a visual inspection and if no damage is visible contact 3SUN's customer service to discuss the next steps of troubleshooting.

7. Liability Disclaimer

The conditions of installation, operation, use and maintenance of PV modules, as well as the choice of the ancillary components in the photovoltaic system (such as, but not limited to, mounting clamps, bolts and structures, cabling, and inverters), are beyond 3SUN's control.

Therefore, 3SUN refuses any legal responsibility and expressly denies liability for any injury to people and/or damages to property, including the PV modules themselves, arising from the failure to follow the instructions provided in this manual and/or an inadequate integration of all the components that form the photovoltaic system; for sake of clarity, the user will be deemed the sole responsible for the choice of components that are either of low-quality or are incompatible with the photovoltaic PV modules.

The non-compliance with the provisions set forth herein voids the manufacturer's duties and obligations under 3SUN's Warranty Terms and Conditions.

The provisions provided in this manual do not entail any expressed or implied warranty of quality and safety, and do not release the user from adopting best diligence during the installation, use, operation, and maintenance of PV modules; this includes contacting 3SUN's customer service in case of need.

3SUN reserves the right to update the content of this manual without prior notice. Please visit our web site regularly at www.3SUN.com to obtain, from time to time, the latest version of this manual.

Version	Publication date	Updates
1.0	20/05/2025	3SUN B48 Product Line Installation Manual First Release
1.0.1	02/09/2025	2.1 Shipping Configuration: The number of mono-packs has been updated from 30 to 28 2.1 Container Unloading Procedure: The number of mono-packs has been updated from 30 to 28

Note: This version of the installation manual replaces the previous one with reference to installation activities carried out from the date of its publication onward.